

8" Encapsulated SUBMERSIBLE MOTORS





Quality in the Well



8" Encapsulated Motors

Optional: **SAND FIGHTER**



Submersible Motors

Quality in the Well

These 8" encapsulated motors, manufactured in ISO 9001 certified facilities, are built for dependable operation in 8" diameter or larger water wells. It is fitted with water lubricated radial and thrust bearings for maintenance-free operation. A special diaphragm ensures pressure compensation inside the motor. The motor is filled with a special FES91 fluid, providing frost protection down to -15°C storage temperature. The Sand fighter® SiC seal system is the option for sandy applications.

Product advantages:

- Hermetically sealed stator, anti track, self healing stator resin prevents motor burn out
- Removable "Water Bloc" lead connector
- Cable material according to drinking water regulations (VDE / ACS / KTW approved)
- Sand slinger and Mechanical seal for high performance in sand
- High efficiency electrical design for low operation cost
- All motors prefilled and 100% tested
- Max. storage temperature -15°C - + 60°C
- Non contaminating FES91 -filled design

Technical Specifications

- 30 ... 150 kW
- 8" NEMA flange
- Protection: IP 68
- Starts per hour: 10
- Installation: vertical/horizontal
- Standard Voltage: 380-415V/50Hz, 460V/60Hz
- Voltage tolerance 50Hz: -10% / +6% U_N [380-415V = (380-10%) – (415+6%)]
- Voltage tolerance 60Hz: $\pm 10\% U_N$
- Motor protection: Select thermal overloads according to DIN 61947-4-1
- Insulation: Class F
- Rated ambient temperature: 30°C
- Cooling flow: min. 0,16 m/s
- Built-in SubMonitor Transmitter
- Motor lead in 8 m length (VDE / ACS / KTW approved)

Options

- Other voltages
- YΔ - start (pos. of cables 90°)
- Motors complete in 316 SS
- PT 100 temperature sensor (sold separately)
- „Sand fighter®“ Motor with SiC- Mechanical seal



8" Standard Model Numbers 50 HZ

P _N [kW]	U _N [V]	Model Number Digit 1 - 6		Model Number Digit 7 – 10 with SubMonitor Transmitter			
		DOL	YΔ	304		316 SS	
				DOL	YΔ	DOL	YΔ
30	220	-	239 400	-	8023	-	-
	380, 400, 415	239 600	239 620	7023	8023	7223	8223
	500,525	239 670	239 720	7023	8023	-	-
37	220	-	239 401	-	8023	-	-
	380, 400, 415	239 601	239 621	7023	8023	7223	8223
	500,525	239 671	239 721	7023	8023	-	-
45	220	-	239 402	-	8023	-	-
	380, 400, 415	239 602	239 622	7023	8023	7223	8223
	500,525	239 672	239 722	7023	8023	-	-
55	220	-	239 403	-	8043	-	-
	380, 400, 415	239 603	239 623	7043	8043	7243	8243
	500,525	239 673	239 723	7043	8043	-	-
75	220	-	239 404	-	8043	-	-
	380, 400, 415	239 604	239 624	7043	8043	7243	8243
	500,525	239 674	239 724	7043	8043	-	-
93	220	-	-	-	-	-	-
	380, 400, 415	239 105	239 125	7019	8019	7219	8219
	500,525	239 175	239 225	7019	8019	-	-
110	220	-	-	-	-	-	-
	380, 400, 415	239 106	239 126	7519	7619	7219	8219
	500,525	239 176	239 226	7519	7619	-	-
130	380, 400, 415	239 107	239 127	7519	7619	7219	8219
	500,525	239 177	239 227	7519	7619	-	-
150	380, 400, 415	239 108	239 128	7519	7619	7219	8219
	500,525	239 178	239 228	7519	7619	-	-

8" Performance Data 50 Hz

P _N [kW]	Thrust F [N]	U _N [V]	n _N [min ⁻¹]	I _N [A]	I _A [A]	η (Eff.) [%] at % load			cos φ (Pf.) at % load			T _N [Nm]	T _A [Nm]
						50	75	100	50	75	100		
30	45 000	380	2890	61	397	85	86	86	0,75	0,84	0,88	98	231
		400	2900	61	418	83	86	86	0,68	0,78	0,84	97	255
		415	2910	62	433	82	85	86	0,62	0,73	0,80	97	275
		500	2890	47	302	85	86	86	0,75	0,84	0,88		
		525	2900	47	318	83	86	86	0,68	0,78	0,84		
37	45 000	380	2905	75	507	85	87	87	0,78	0,85	0,89	122	266
		400	2920	74	534	84	87	87	0,71	0,81	0,86	121	295
		415	2925	74	554	83	86	87	0,66	0,76	0,83	121	317
		500	2905	57	385	85	87	87	0,78	0,85	0,89		
		525	2920	57	404	84	87	87	0,71	0,81	0,86		
45	45 000	380	2910	89	612	86	87	87	0,77	0,85	0,89	146	363
		400	2920	89	645	85	87	87	0,71	0,81	0,85	145	395
		415	2925	89	669	84	86	87	0,65	0,76	0,82	146	428
		500	2910	68	466	86	87	87	0,77	0,85	0,89		
		525	2920	68	494	85	87	87	0,71	0,81	0,85		
55	45 000	380	2910	111	819	86	88	88	0,79	0,86	0,89	182	507
		400	2920	108	862	85	87	88	0,72	0,82	0,87	182	563
		415	2925	108	895	84	87	88	0,67	0,78	0,84	182	605
		500	2910	85	623	86	88	88	0,79	0,86	0,89		
		525	2920	83	661	85	87	88	0,72	0,82	0,87		
75	45 000	380	2920	153	1099	86	88	88	0,79	0,83	0,86	243	506
		400	2925	151	1157	85	87	87	0,72	0,82	0,83	242	561
		415	2930	151	1200	84	87	87	0,67	0,78	0,80	242	603
		500	2920	113	835	86	88	88	0,79	0,86	0,89		
		525	2925	111	861	85	87	87	0,72	0,82	0,87		
93	45 000	380	2920	194	1265	85	87	87	0,75	0,83	0,86	303	511
		400	2930	190	1332	84	86	87	0,68	0,78	0,83	302	567
		415	2935	191	1382	83	86	87	0,63	0,74	0,80	302	610
		500	2920	148	961	85	87	87	0,75	0,83	0,86		
		525	2930	145	1015	84	86	87	0,68	0,78	0,83		
110	45 000	380	2920	226	1517	86	88	88	0,77	0,84	0,87	364	694
		400	2930	222	1597	85	87	88	0,70	0,80	0,84	363	769
		415	2935	223	1657	84	87	88	0,64	0,75	0,81	363	828
		500	2920	172	1153	86	88	88	0,77	0,84	0,87		
		525	2930	170	1217	85	87	88	0,70	0,80	0,84		
130	45 000	380	2910	260	1651	86	87	87	0,83	0,87	0,89	425	837
		400	2920	252	1738	86	87	88	0,79	0,84	0,87	424	927
		415	2930	247	1803	85	87	88	0,74	0,81	0,86	423	1153
		500	2910	198	1255	86	87	87	0,83	0,87	0,89		
		525	2920	192	1324	86	87	88	0,79	0,84	0,87		
150	45 000	380	2910	294	1765	86	88	88	0,83	0,88	0,90	487	933
		400	2920	284	1858	86	88	88	0,79	0,86	0,88	485	1034
		415	2930	277	1928	86	88	88	0,75	0,83	0,87	485	1113
		500	2910	224	1341	86	88	88	0,83	0,88	0,90		
		525	2920	217	1416	86	88	88	0,79	0,86	0,88		



Winding Resistances 50 Hz

P _N [kW]	U _N [V]	3 ~ DOL		3 ~ YΔ	
		Stator Ref.	U - V / Ohm V - W / Ohm U - W / Ohm	Stator Ref.	U ₁ - U ₂ / Ohm V ₁ - V ₂ / Ohm W ₁ - W ₂ / Ohm
30	220	-	-	338 382 ...	0.123 - 0.150
	380, 400, 415	338 382 ...	0.247 - 0.302	338 443 ...	0.345 - 0.423
	500, 525	338 610 ...	0.399 - 0.487	338 610 ...	0.621 - 0.759
37	220	-	-	338 383 ...	0.090 - 0.111
	380, 400, 415	338 383 ...	0.181 - 0.221	338 588 ...	0.272 - 0.332
	500, 525	338 611 ...	0.280 - 0.342	338 611 ...	0.464 - 0.566
45	220	-	-	338 384 ...	0.071 - 0.087
	380, 400, 415	338 384 ...	0.142 - 0.174	338 645 ...	0.210 - 0.257
	500, 525	338 612 ...	0.227 - 0.277	338 612 ...	0.369 - 0.450
55	220	-	-	338 385 ...	0.053 - 0.065
	380, 400, 415	338 385 ...	0.105 - 0.128	338 646 ...	0.164 - 0.200
	500, 525	338 613 ...	0.169 - 0.207	338 613 ...	0.267 - 0.327
75	220	-	-	338 386 ...	0.036 - 0.045
	380, 400, 415	338 386 ...	0.073 - 0.089	338 591 ...	0.102 - 0.125
	500, 525	338 614 ...	0.129 - 0.158	338 614 ...	0.198 - 0.243
93	380,400,415	336 053 ...	0.055 - 0.067	336 053 ...	0.083 - 0.101
	500, 525	338 514 ...	0.091 - 0.112	338 514 ...	0.137 - 0.168
110	380,400,415	336 054 ...	0.046 - 0.056	336 054 ...	0.069 - 0.084
	500, 525	338 515 ...	0.086 - 0.106	338 515 ...	0.129 - 0.159
130	380,400,415	336 524 ...	0.042 - 0.052	336 524 ...	0.063 - 0.078
	500, 525	338 516 ...	0.073 - 0.090	338 516 ...	0.110 - 0.135
150	380,400,415	336 055 ...	0.036 - 0.044	336 055 ...	0.054 - 0.066
	500, 525	337 071 ...	0.057 - 0.070	337 071 ...	0.086 - 0.105

VDE / KTW Approved Leads* 304 / 316SS

3 ~ DOL start

	P _N [kW]	Ø	Size [mm]	Type	Qty.	L (m)	Part numbers	
							304	316SS
	30 - 45	1x 4G8,4 mm ²	B 29,5 / H 8,9	VDE/KTW	1	8	305 312 901	305 312 911
							55 - 93	3 x (1X16 mm ²)
	110 - 150*	3 x (1X35 mm ²)	Ø 14,5 (±0,3)	VDE/KTW	1	8	305 309 901	

* 3 Leads with single conductors

3 ~ YΔ Start (Pos. of cables 90°)

	P _N [kW]	Ø	Size [mm]	Type	Qty.	L (m)	Part numbers	
							304	316SS
	30 - 45	1x 4G8,4 mm ²	B 29,5 / H 8,9	VDE/KTW	1	8	305 312 902	305 312 912
		1x 3X8,4 mm ²	B 19,6 / H 8,9					
	55 - 150	3 x (1X16 mm ²)	D 11,6 (±0,2)	VDE/KTW	2	8	305 310 901	305 310 951

Ground Leads

	P _N [kW]	Ø	Size [mm]	Type	Qty.	L (m)	Part numbers
							304/316SS
	55 - 150	1G25 mm ²	D 13 mm (±0,3)	VDE/KTW	1	8	308 053 080

* Cables are designed for submerged operation. For air operation please consult Franklin Electric.

8" Encapsulated Cast Iron

30 - 45 kW Type 2.1***

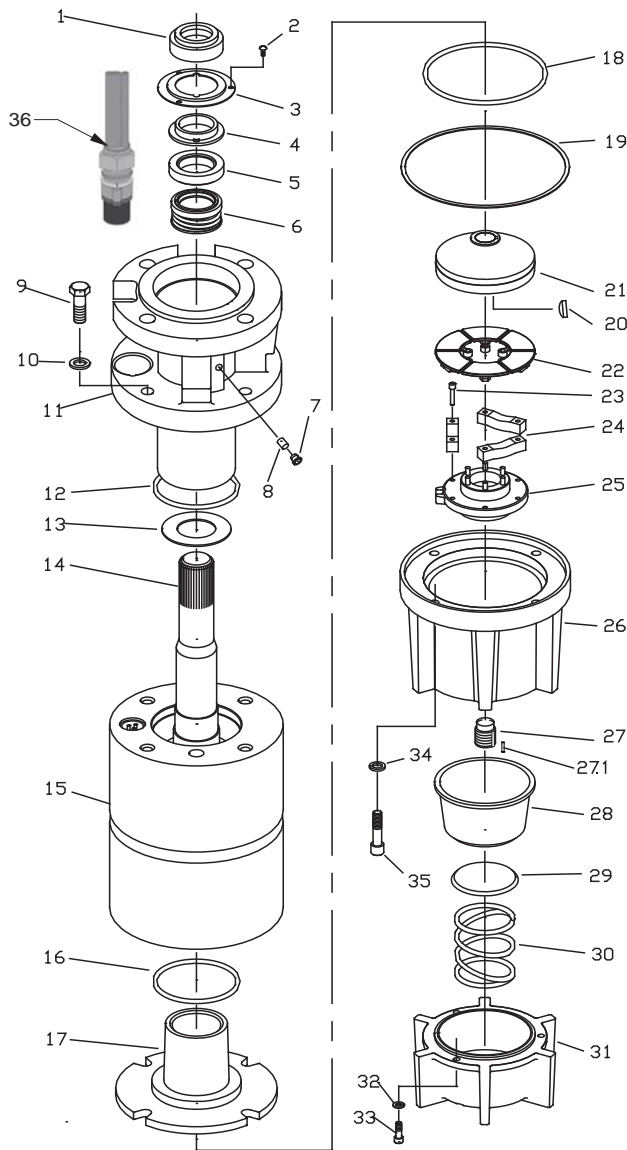

Position	Part Description	Qty	Kit
1	Rubber Slinger	1	B
2	Bushing Cover Screw	3	B, F
3	Bushing Cover	1	B
4	Slinger Bushing	1	B
5, 6	Shaft Seal	1	B
7	Filter Assembly	1	B
8	Valve Assembly	1	B
9, 10	Screw/Lockwasher	4	C, D, F
11	End Bell, Upper w/Radial Brg	1	C, D
12	O-Ring	1	B, C, D
13	Upthrust Washer	1	A
14	Rotor	1	see page 97
15	Stator	1	see page 97
16	O-Ring	1	B, E
17	End Bell, Lower w/Radial Brg	1	E
18	O-Ring	1	B, E
19	Gasket	1	B
20	Woodruff Key	1	A
21	Thrust Disc Asm	1	A
22, 23, 24, 25	Thrust Segment Asm	1	A
26	Thrust Housing	1	G
27	Adjusting Screw	1	A
27.1	Pin (Brass)	1	A
28	Diaphragm	1	B
29	Spring Plate	1	B
30	Diaphragm Spring	1	B
31	Diaphragm Cover	1	H
32, 33	Screw/Lockwasher	3	F, H
34, 35	Screw/Lockwasher	4	F, G
36	Lead	1/2	see page 94

	Description	Includes Pos.	Part Number
Kit A 40 - 60 HP	Thrust Bearing	13, 19 - 25, 27, 27.1	305 428 001
Kit B 40 - 60 HP	Seal Carbon/Ceramic	1 - 8, 12, 16, 18, 19, 28 - 30	305 428 002
Kit B1 40 - 60 HP	Seal SiC	1 - 8, 12, 16, 18, 19, 28 - 30	305 428 011
Kit C1 40 - 60 HP 3 Lead	End Bell, Upper	9 - 12	305 428 003
Kit D1 40 - 60 HP 6 Lead	End Bell, Upper	9 - 12	305 428 005
Kit E 40 - 60 HP	End Bell, Lower*	16 - 18	305 428 007
Kit F 40 - 60 HP	Fasteners*	2, 9, 10, 32 - 35	305 428 017
Kit G 40 - 60 HP	Thrust Housing	26, 34, 35	305 428 009
Kit H 40 - 60 HP	Diaphragm Cover	31 - 33	305 428 010
Kit I 40 - 60 HP	Radial Bearing**	SS Sleeve & Carbon Bushing	305 428 054

* Suitable for 304 and 316SS Motors

** Parts are Semi finished

*** Spare parts for motors build up to June 2015 please contact FE



8" Encapsulated 304

55 - 150 kW Type 1

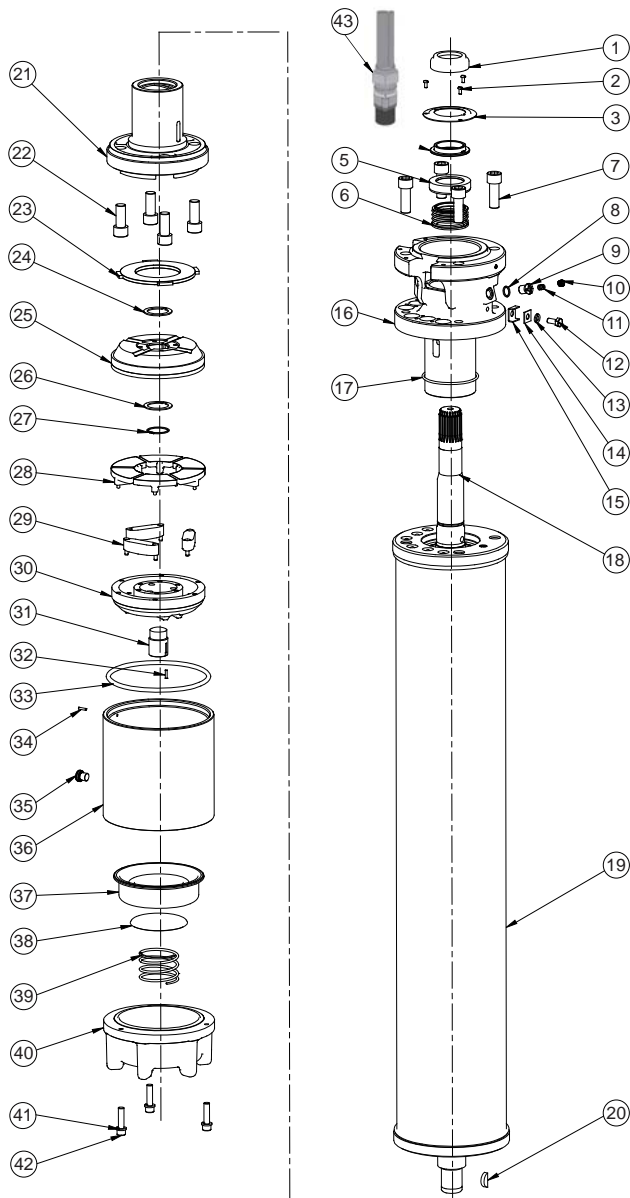

Position	Part Description	Qty	Kit
1	Rubber Slinger	1	B
2	Bushing Cover Screw	3	B, F
3	Bushing Cover	1	B
4	Slinger Bushing	1	B
5, 6	Shaft Seal	1	B
7	Screw/Lockwasher	4	C, D, F
8, 9, 11	Valve Assembly	1	B, C, D
10	Filter Assembly	1	B
12, 13, 14, 15	Ground Lug Asm	1	C, D
16	End Bell, Upper w/Radial Brg	1	C, D
17	O-Ring	1	B, C, D
18	Rotor	1	see page 97
19	Stator	1	see page 97
20	Woodruff Key	1	A
21	End Bell, Lower w/Radial Brg	1	E
22	Screw	4	E, F
23	Upthrust Washer	1	A 155 318 201K
24, 26, 27	Shim/Retainer Ring	1	A
25	Thrust Disc Asm	1	A
28, 29, 30	Thrust Segment Asm	1	A
31	Adjusting Screw	1	A
32	Pin	1	A
33	O-Ring	1	A, E
34, 36	Thrust Housing	1	G
35	Plug	1	--
37	Diaphragm	1	B
38	Spring Plate	1	B
39	Diaphragm Spring	1	B
40	Diaphragm Cover	1	H
41, 42	Screw/Lockwasher	3	F, H
43	Lead	3 / 6	see page 94

	Description	Includes Pos.	Part Number
Kit A 75 - 200 HP	Thrust Bearing	20, 23 - 33	305 428 020
Kit B1 75 - 200 HP	Seal Kit	1 - 6, 10, 11, 17, 32, 33, 37 - 39	305 428 021
Kit B2 75 - 200 HP	Seal SiC ***	1 - 6, 10, 11, 17, 32, 33, 37 - 39	305 428 022
Kit C1 75 HP 3 Lead	End Bell, Upper	7, 11 - 17	305 428 023
Kit C2 150 - 200 HP 3 Lead	End Bell, Upper	7, 11 - 17	305 428 024
Kit D 75 - 200 HP 6 Lead	End Bell, Upper	7, 11 - 17	305 428 025
Kit E 75 - 200 HP	End Bell, Lower*	21, 22, 32, 33	305 428 037
Kit F 75 - 200 HP	Fasteners*	2, 7, 22, 41, 42	305 428 039
Kit G 75 - 200 HP	Thrust Housing	34, 36	305 428 029
Kit H 75 - 200 HP	Diaphragm Cover	40 - 42	305 428 030
Kit I 75 - 200 HP	Radial Bearing**	SS Sleeve & Carbon Bushing	305 428 055

* Suitable for 304 and 316SS Motors

** Parts are Semi finished

*** Spring DM 62,7mm for 125 - 200 HP only

Replacement Stators and Rotors 304 / 50 Hz
3 ~ Direct start with SubMonitor Transmitter

P_N [kW]	U_N [V]	Motor Model No.	Stator	Rotor
30	380, 400, 415	239 600 7023	305 500 901	575 122 925
	500, 525	239 670 7023	338 610 902	
37	380, 400, 415	239 601 7023	305 501 901	575 122 930
	500, 525	239 671 7023	338 611 903	
45	380, 400, 415	239 602 7023	305 502 901	575 122 931
	500, 525	239 672 7023	338 612 904	
55	380, 400, 415	239 603 7043	338 386 915	575 122 920
	500, 525	239 673 7043	338 613 902	
75	380, 400, 415	239 604 7043	338 386 915	575 122 921
	500, 525	239 674 7043	338 614 907	
93	380, 400, 415	239 105 7019	305 505 901	575 122 922
	500, 525	239 175 7019	338 514 951	
110	380, 400, 415	239 106 7519	305 506 902	575 122 923
	500, 525	239 176 7519	338 515 951	
130	380, 400, 415	239 107 7519	336 524 101	575 122 924
	500, 525	239 177 7519	*	
150	380, 400, 415	239 108 7519	336 055 905	575 122 918
	500, 525	239 178 7519	337 071 912	

Replacement Stators and Rotors 304 / 50 Hz
3 ~ YΔ Start with SubMonitor Transmitter (Pos. of cables 90°)

P_N [kW]	U_N [V]	Motor Model No.	Stator	Rotor
30	220	239 400 8023	338 382 911	575 122 925
	380, 400, 415	239 620 8023	305 500 503	
	500, 525	239 720 8023	338 610 904	
37	220	239 401 8023	305 501 903	575 122 930
	380, 400, 415	239 621 8023	305 501 904	
	500, 525	239 721 8023	338 611 906	
45	220	239 402 8023	305 502 902	575 122 931
	380, 400, 415	239 622 8023	305 502 905	
	500, 525	239 722 8023	338 612 906	
55	220	239 403 8043	305 503 904	575 122 920
	380, 400, 415	239 623 8043	305 503 909	
	500, 525	239 723 8043	338 613 906	
75	220	239 404 8043	338 386 904	575 122 921
	380, 400, 415	239 624 8043	305 504 904	
	500, 525	239 724 8043	305 504 908	
93	380, 400, 415	239 125 8019	305 505 903	575 122 922
	500, 525	239 225 8019	305 505 910	
110	380, 400, 415	239 126 7619	305 506 903	575 122 923
	500, 525	239 226 7619	338 515 952	
130	380, 400, 415	239 127 7619	336 524 917	575 122 924
	500, 525	239 227 7619	338 516 902	
150	380, 400, 415	239 128 7619	336 055 919	575 122 918
	500, 525	239 228 7619	337 071 914	



8" Encapsulated 316SS

30 - 45 kW Type 2.1***

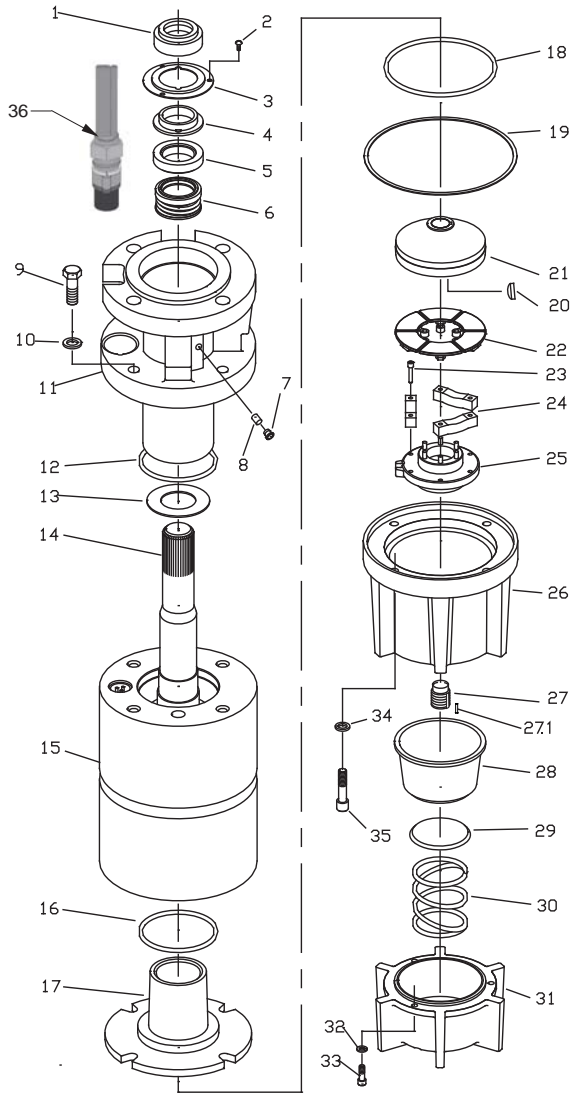

Position	Part Description	Qty	Kit
1	Rubber Slinger	1	B
2	Bushing Cover Screw	3	B, F
3	Bushing Cover	1	B
4	Slinger Bushing	1	B
5, 6	Shaft Seal	1	B
7	Filter Assembly	1	B
8	Valve Assembly	1	B
9, 10	Screw/Lockwasher	4	C, D, F
11	End Bell, Upper w/Radial Brg	1	C, D
12	O-Ring	1	B, C, D
13	Upthrust Washer	1	A, B1 155 941 101
14	Rotor	1	see page 100
15	Stator	1	see page 100
16	O-Ring	1	B, E
17	End Bell, Lower w/Radial Brg	1	E
18	O-Ring	1	B, E
19	Gasket	1	B
20	Woodruff Key	1	A
21	Thrust Disc Asm	1	A
22, 23, 24, 25	Thrust Segment Asm	1	A
26	Thrust Housing	1	G
27	Adjusting Screw	1	A
27.1	Pin (Brass)	1	A
28	Diaphragm	1	B
29	Spring Plate	1	B
30	Diaphragm Spring	1	B
31	Diaphragm Cover	1	H
32, 33	Screw/Lockwasher	3	F, H
34, 35	Screw/Lockwasher	4	F, G
36	Lead	1/2	see page 94

	Description	Includes Pos.	Part Number
Kit A	40 - 60 HP Thrust Bearing*	13, 19 - 25, 27, 27.1	305 428 001
Kit B	40 - 60 HP Seal Kit	1 - 8, 12, 16, 18, 19, 28 - 30	305 428 012
Kit C1	40 - 60 HP 3 Lead End Bell, Upper	9 - 12	305 428 013
Kit D1	40 - 60 HP 6 Lead End Bell, Upper	9 - 12	305 428 015
Kit E	40 - 60 HP End Bell, Lower*	16 - 18	305 428 007
Kit F	40 - 60 HP Fasteners*	2, 9, 10, 32 - 35	305 428 017
Kit G	40 - 60 HP Thrust Housing	26, 34, 35	305 428 018
Kit H	40 - 60 HP Diaphragm Cover	31 - 33	305 428 019
Kit I	40 - 60 HP Radial Bearing**	SS Sleeve & Carbon Bushing	305 428 054

* Suitable for 304 and 316SS Motors

** Parts are Semi finished

*** Spare parts for motors build up to june 2015 please contact FE

8" Encapsulated 316SS

55 - 150 kW Type 1

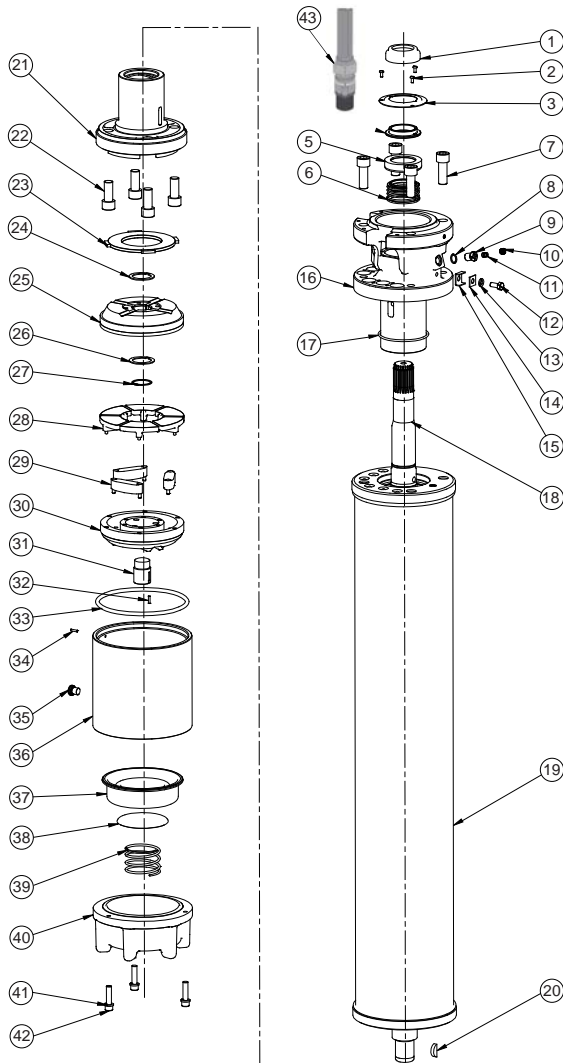

Position	Part Description	Qty	Kit
1	Rubber Slinger	1	B
2	Bushing Cover Screw	3	B, F
3	Bushing Cover	1	B
4	Slinger Bushing	1	B
5, 6	Shaft Seal	1	B
7	Screw/Lockwasher	4	C, D, F
8, 9, 11	Valve Assembly	1	B, C, D
10	Filter Assembly	1	B
12, 13, 14, 15	Ground Lug Asm	1	C, D
16	End Bell, Upper w/Radial Brg	1	C, D
17	O-Ring	1	B, C, D
18	Rotor	1	see page 100
19	Stator	1	see page 100
20	Woodruff Key	1	A
21	End Bell, Lower w/Radial Brg	1	E
22	Screw	4	E, F
23	Upthrust Washer	1	A
24, 26, 27	Shim/Retainer Ring	1	A
25	Thrust Disc Asm	1	A
28, 29, 30	Thrust Segment Asm	1	A
31	Adjusting Screw	1	A
32	Pin	1	A
33	O-Ring	1	A, E
36	Thrust Housing	1	G
35	Plug	1	--
37	Diaphragm	1	B
38	Spring Plate	1	B
39	Diaphragm Spring	1	B
40	Diaphragm Cover	1	H
41, 42	Screw/Lockwasher	3	F, H
43	Lead	3 / 6	see page 94

	Description	Includes Pos.	Part Number
Kit A 75 - 200 HP	Thrust Bearing	20, 23 - 33	305 428 020
Kit B 75 - 200 HP	Seal SiC***	1 - 6, 10, 11, 17, 32, 33, 37 - 39	305 428 033
Kit C1 75 HP 3 Lead	End Bell, Upper	7, 11 - 17	305 428 034
Kit C2 150 - 200 HP 3 Lead	End Bell, Upper	7, 11 - 17	305 428 035
Kit D 75 - 200 HP 6 Lead	End Bell, Upper	7, 11 - 17	305 428 036
Kit E 75 - 200 HP	End Bell, Lower*	21, 22, 32, 33	305 428 037
Kit F 75 - 200 HP	Fasteners*	2, 7, 22, 41, 42	305 428 039
Kit G 75 - 200 HP	Thrust Housing	34, 35, 36	305 428 040
Kit H 75 - 200 HP	Diaphragm Cover	40 - 42	305 428 041
Kit I 75 - 200 HP	Radial Bearing**	SS Sleeve & Carbon Bushing	305 428 055

* Suitable for 304 and 316SS Motors

** Parts are Semi finished

*** Spring DM 62,7mm for 125 - 200 HP only



Replacement Stators and Rotors 316SS/ 50 Hz

3 ~ Direct start with SubMonitor Transmitter

P_N [kW]	U_N [V]	Motor Model No.	Stator	Rotor
30	380, 400, 415	239 600 7223	305 500 902	575 122 925
37	380, 400, 415	239 601 7223	305 501 902	575 122 930
45	380, 400, 415	239 602 7223	305 502 903	575 122 931
55	380, 400, 415	239 603 7243	338 385 915	575 122 920
75	380, 400, 415	239 604 7243	338 386 915	575 122 921
93	380, 400, 415	239 105 7219	305 505 902	575 122 922
110	380, 400, 415	239 106 7219	305 506 906	575 122 923
130	380, 400, 415	239 107 7219	336 524 915	575 122 924
150	380, 400, 415	239 108 7219	336 055 916	575 122 918

3 ~ YΔ Start with SubMonitor Transmitter (Pos. of cables 90°)

P_N [kW]	U_N [V]	Motor Model No.	Stator	Rotor
30	380, 400, 415	239 620 8223	338 443 904	575 122 925
37	380, 400, 415	239 621 8223	338 588 904	575 122 930
45	380, 400, 415	239 622 8223	305 502 906	575 122 931
55	380, 400, 415	239 623 8223	338 646 906	575 122 920
75	380, 400, 415	239 624 8223	338 591 908	575 122 921
93	380, 400, 415	239 125 8219	305 505 904	575 122 922
110	380, 400, 415	239 126 8219	305 506 905	575 122 923
130	380, 400, 415	239 127 8219	336 524 918	575 122 924
150	380, 400, 415	239 128 8219	305 508 904	575 122 918

Electrical Connection

DOL	YΔ								
<table border="1" style="margin: auto;"> <thead> <tr> <th>U</th> <th>V</th> <th>W</th> <th>PE</th> </tr> </thead> <tbody> <tr> <td>black</td> <td>grey</td> <td>brown</td> <td>yellow/green</td> </tr> </tbody> </table>		U	V	W	PE	black	grey	brown	yellow/green
U	V	W	PE						
black	grey	brown	yellow/green						

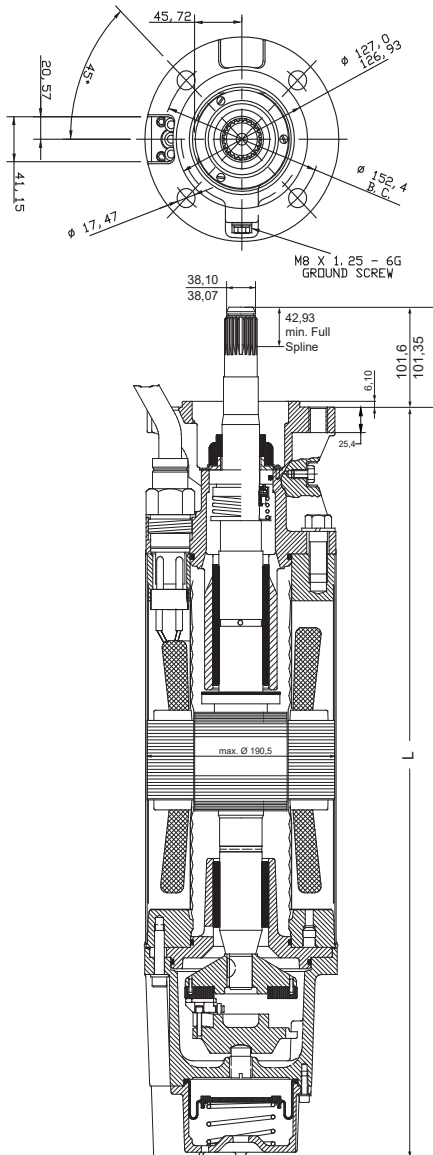
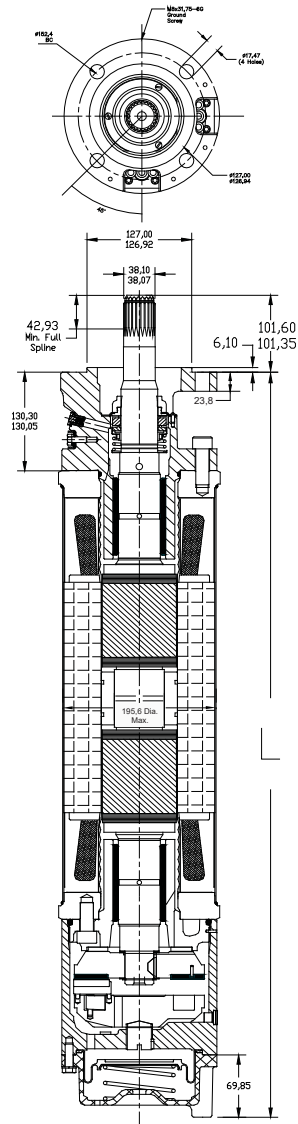
8" Outline Drawings 304 / 316 SS
30 - 45 kW

55 - 150 kW

Material DIN / AISI

Parts	304 SS	316 SS
Shell	1.4301	1.4571
Upper end bell	Cast iron powder coated	1.4408
Lower end bell	Cast iron 20	1.4401
Thrust housing	Cast iron powder coated	1.4408
Mechanical seal	Carbon/Ceramic*	SiC
Seal cover	1.4301	1.4401
Slinger	BUNA N	Hydrin 100
Shaft end	1.4305	1.4542
Diaphragm	BUNA N	Hydrin
Cable	EPR	EPR
Cap screw (cable)	Brass	1.4401
Lead sleeve	Brass, Ni-plated	1.4401
Lead bushing	Rubber	Rubber
Other seals	BUNA N	BUNA N

* 30 - 45 kW C / C ; 55 - 150 kW SiC

Lengths & Weights

P _N [kW]	" L " Dim. [mm]	Shipping Weight [kg]	Shipping Size [mm]
30	925	145	228 x 430 x 1308
37	1000	157	228 x 430 x 1308
45	1077	172	228 x 430 x 1308
55	1264	227	228 x 430 x 1632
75	1455	265	228 x 447 x 1981
93	1748	318	228 x 447 x 1981
110	1976	381	228 x 447 x 2438
130	2179	420	228 x 447 x 2438
150	2408	494	228 x 447 x 2438

SubMonitor Motor Protection

The SubMonitor is designed to protect 3-phase pumps with horsepower ratings between 3 and 200 Hp. Current, voltage and motor temperature are monitored using three integrated current transformers. A digital display provides current and voltage readings for all three legs and allows the user to set up the SubMonitor quickly and easily. The SubMonitor is the latest innovation in 3-phase pump protection from Franklin Electric. Using state-of-the-art technology, the SubMonitor provides the ultimate protection for a pump and motor. There is simply no better way to protect a large 3-phase submersible pump investment than with a SubMonitor. It's the protection device that can sense overheating straight from the motor windings! And it is made by the world leader in submersible motors - Franklin Electric.



Product advantages:

- Quick setup to monitor a motor, simply enter the Line Frequency (Hz), Line Voltage (volts), and Motor Service Factor Amp rating
- Digital display indicates voltage and current on all three legs at the same time, and fault messages are in easily understandable text
- Monitors - Under/Overload; Under/Overtension; Current Unbalance; Overheated Motor (Subtrol Equipped); False Start (Chattering); Phase Reversal
- For motors with service factor amp ratings between 3 and 359 amps
- One unit covers the entire range from 190 to 600 Volts
- No need to make additional turns around the CT or add external CTs
- Password Protection Option
- DIN Rail Mounting Option
- Stores fault, setting changes, and pump run-time, that can be accessed through the display
- Detachable NEMA 3R display unit can be mounted on panel door
- UL 508 Listed

Model number	
Premium Package	586 000 5100
Input Voltage	190 – 600 VAC
Frquency	60/50 Hz
Motor Service Factor Amps	3 to 359 Amps
Maximum Conductor Size Through Sensors	
Max. Diameter	0.920 in. (23 mm)
Trip Response	
Motor, Under / Overload, Under / Overtension, Overheat Unbalance	3 seconds
Control Circuit Rating	1.5 Amp AC, up to 600 volts
Signal Circuit Rating	1 Amp AC, up to 250 volts (Incandescent: 100 watts max.)
Wiring Terminals	
Wire Gauge	#12 to #18 AWG
Tighten to	4.5 in-lbs
Weight (SubMonitor)	3.3 lbs/7,3 kg
Carton Size (Std. Unit)	7,75 in x 11,5 in x 6,75 in (19,7 cm x 29,2 cm x 17,1 cm)
Shipping Weight (Std. Unit)	3.5 Lbs./7.5 kg

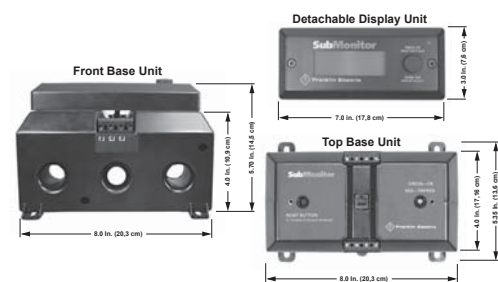

SubMonitor Accessory



D3 Data Download Tool

D3 is a service tool that provides the capability to download data from SubMonitor and transfer that data to a PC.

Includes:

- D3 unit
- Transfer software
- USB cable



Part Nb.: 585 001 1100

Motor Filling Liquid

Filling liquid 5 L FES92					
4" Encapsulated	→	FES93	8" Encapsulated Standard	→	FES91
6" Encapsulated Standard	→	FES91	8" Encapsulated HighTemp75	→	FES92
6" Encapsulated HighTemp90	→	FES92	6" / 8" / 10" / 12" Rew Motors 6" / 8" Rew PM Motors		FES93

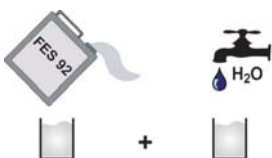

**Part number:
308 353 941**

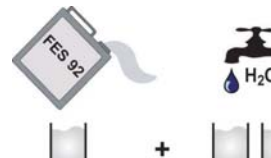
FES91	FES92	FES93
		

Motor Filling Kit

This kit contains all necessary tools to check and replenish Franklin Electric submersible motors with FES 91, 92 or 93 filling liquid (fill solution/concentrate must be ordered separately).

Part number: 308 726 103





8" Motor-Pump Couplings

**Outline
Drawing:**

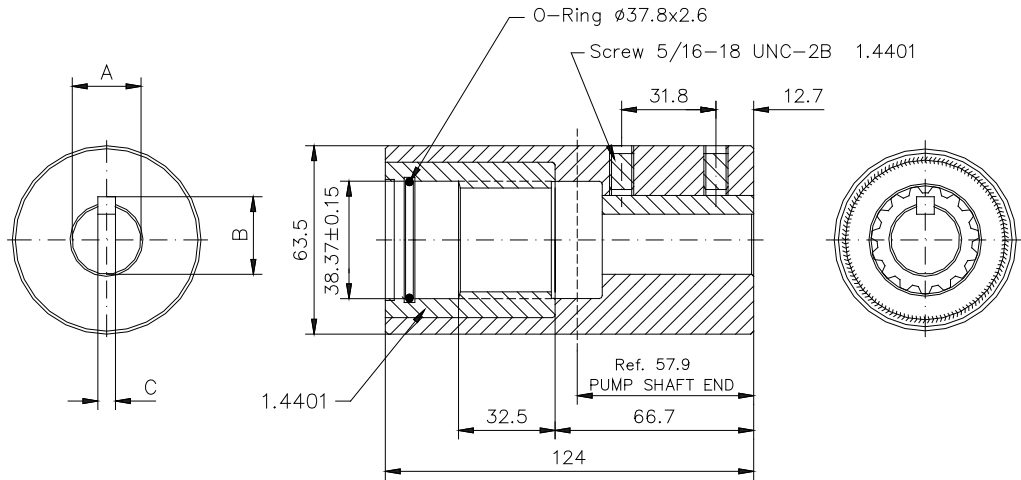

**Ordering
information**

Part No.	Coupling Material DIN / AISI	Dimension A (mm) Max. / Min.	Dimension B (mm) Max. / Min.	Dimension C (mm) Max. / Min.
156 563 901	1.4005 (304)	25,425 / 25,413	28,27 / 28,17	6,38 / 6,32
156 563 921	1,4404 (316SS)			
156 563 902	1.4005 (304)	30,188 / 30,175	33,73 / 33,63	7,96 / 7,91
156 563 922	1,4404 (316SS)			
156 563 903	1.4005 (304)	31,775 / 31,763	35,36 / 35,26	7,96 / 7,91
156 563 923	1,4404 (316SS)	38,125 / 38,113		
156 563 904	1.4005 (304)	38,125 / 38,113	42,37 / 42,27	9,55 / 9,50
156 563 924	1,4404 (316SS)	38,125 / 38,113		
156 563 905	1.4005 (304)	19,085 / 19,063	20,70 / 20,52	4,84 / 4,79
156 563 906	1.4005 (304)	30,188 / 30,175	33,02 / 32,92	6,38 / 6,32
156 563 926	1,4404 (316SS)	30,188 / 30,175	33,02 / 32,92	6,38 / 6,32
156 563 907	1.4005 (304)	22,250 / 22,238	24,54 / 24,36	6,43 / 6,38
156 563 908	1.4005 (304)	22,024 / 22,011	25,53 / 25,32	8,03 / 7,98
156 563 931	1,4404 (316SS)			
156 563 929	1,4404 (316SS)	42,888 / 42,850	47,12 / 47,04	9,55 / 9,50
156 563 909	1.4005 (304)	25,024 / 25,011	28,70 / 28,30	8,03 / 7,98
156 563 932	1,4404 (316SS)			

PT100 for 6" and 8" Encapsulated Motors

The PT100 is a precision platinum wire resistor that is specified occasionally as a temperature input for process control equipment. A jacketed control lead must be run from the PT100 lead to the above-ground equipment. The above-ground equipment is not available from Franklin Electric and is typically part of a custom panel or data acquisition system.

PT100 sensor retrofit kits from Franklin Electric come with complete instructions and allow for easy field installation.

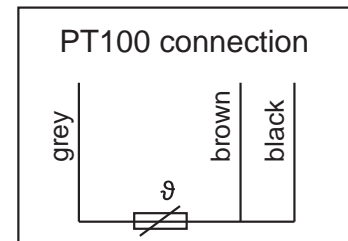
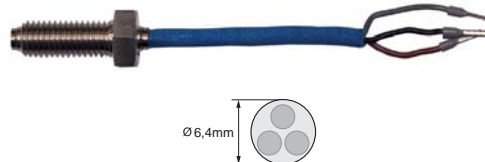
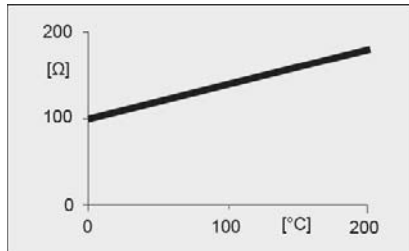

To install the PT100 sensor bolt, remove the top end bell bolt that is opposite of the lead and replace it with the PT100 screw. Tighten the sensor bolt to the torque values shown below.

6" PT100 - 4kW- 45kW	54- 61 Nm
8" PT100 - 30kW- 45kW	54- 61 Nm
55kW- 150kW	115- 122 Nm

Franklin Electric does not offer the required sensing device, it is available from speciality dealers.

Conditions	Temp. of the water without motor operation	Max. Trip temp. / Resistance Setting (for standard Lead length)
Motor operating at nameplate output with 0.16 m/sec flow past the motor	10°C	40°C / 115,5 Ω
	15°C	44°C / 117,0 Ω
	20°C	48°C / 118,6 Ω
	25°C	51°C / 119,7 Ω
	30°C	55°C / 121,3 Ω
Motor that has been <u>Derated</u> with 1 m/sec flow past the motor	35°C	59°C / 122,8 Ω
	40°C	63°C / 124,3 Ω
	45°C	66°C / 125,5 Ω
	50°C	70°C / 127,0 Ω
	55°C	74°C / 128,6 Ω
	60°C	78°C / 130,1 Ω



8" PT100 CT

Kit Number	Motor Type	Wire Insul.	max. Medium Temp.	Lead (mm ²)	Lead length (m)
305 326 902	30 - 45kW (Type 2.1)	Rubber	60°C	3X0,5	10
305 326 901	55 - 150kW (Type 1)	Rubber	60°C	3X0,5	10



Franklin Electric Europa GmbH
Rudolf Diesel Strasse 20
54516 Wittlich / Germany

franklinwater.eu

082017