

6" Encapsulated HighTemp 90 SUBMERSIBLE MOTORS





Quality in the Well



6" Encapsulated Motor

„HighTemp 90°C“

Standard:

SAND FIGHTER



Submersible Motors

Quality in the Well

These 6" encapsulated motors, manufactured in ISO 9001 certified facilities, are built for dependable operation in 6" diameter or larger water wells with ambient temperature up to 90°C.

Water lubricated thrust and radial bearings enable a maintenance free operation. A special diaphragm ensures pressure compensation inside the motor. The motor is filled with a special FES92 fluid, providing frost protection down to -15°C storage temperature.

The Sand fighter® SiC seal system is standard.

Product advantages:

- Up to 90°C ambient temperature
- Increase thrust capacity up to 30°C
- No cooling flow in larger wells (12" / open reservoirs) up to 30°C ambient
- Hermetically sealed encapsulated stator, anti track, self healing stator resin
- Removable "Water Bloc" lead connector
- „Sand fighter®“ Motor with SiC-Mechanical Seal
- High efficiency electrical design for low operation cost
- All motors prefilled and 100% tested. Max. storage temperature -15°C - + 60°C
- High temperature leads
- Non contaminating FES92 -filled design
- 45kN Thrust Bearing Capacity is Standard

Technical Specifications

- 3,7 ... 30 kW
- 6" NEMA double flange
- Protection: IP 68
- Starts per hour: 20
- Installation: vertical/horizontal
- Standard Voltage: 380-415V/50Hz, 460V/60Hz
- Voltage tolerance 50Hz: -10% / +6% U_N [380-415V = (380-10%) – (415+6%)]
- Voltage tolerance 60Hz: $\pm 10\% U_N$
- Motor protection: Select thermal overloads according to DIN 61947-4-1
- Insulation: Class F
- Rated ambient temperature: 90°C
- Cooling flow: min. 0,16 m/s
- DOL / YΔ - start (pos. of cables 90°)
- Motor lead in 4m length

Options

- Other voltages
- Motors complete in 316 SS

6" HighTemp90 Model Numbers 50 Hz

P _N [kW]	P _N [Hp]	U _N [V]	Model Number Digit 1 – 6		Model Number Digit 7 - 11	
			DOL	Y Δ	304	316SS
3,7	5	380 - 415	276 610	276 710	0000	3000
5,5	7,5	380 - 415	276 611	276 711	0000	3000
7,5	10	380 - 415	276 612	276 712	0000	3000
11	15	380 - 415	276 613	276 713	0000	3000
15	20	380 - 415	276 614	276 714	0000	3000
18,5	25	380 - 415	276 615	276 715	0100	3100
22	30	380 - 415	276 616	276 716	0100	3100
30	40	380 - 415	276 617	276 717	0100	3100

6" HighTemp90 Model Numbers 60 Hz

P _N [kW]	P _{max.} [kW]	U _N [V]	Model Number Digit 1 – 6		Model Number Digit 7 - 11		
			DOL	Y Δ	304	316SS	High Thrust 45000N Motor Version
3,7	4,3	230	276 600	276 720	0000X	3000X	**63X
		380	276 660	276 780	0000X	3000X	**63X
		460	276 610	276 710	0000X	3000X	**63X
5,5	6,3	230	276 601	276 721	0000X	3000X	**63X
		380	276 661	276 781	0000X	3000X	**63X
		460	276 611	276 711	0000X	3000X	**63X
7,5	8,6	230	276 602	276 722	0000X	3000X	**63X
		380	276 662	276 782	0000X	3000X	**63X
		460	276 612	276 712	0000X	3000X	**63X
11	12,6	230	276 603	276 723	0000X	3000X	**63X
		380	276 663	276 783	0000X	3000X	**63X
		460	276 613	276 713	0000X	3000X	**63X
15	17,2	230	276 604	276 724	0000X	3000X	**63X
		380	276 664	276 784	0000X	3000X	**63X
		460	276 614	276 714	0000X	3000X	**63X
18,5	21,3	230	276 605	276 725	0100X	3100X	**63X
		380	276 665	276 785	0100X	3100X	**63X
		460	276 615	276 715	0100X	3100X	**63X
22	25,3	230	276 606	276 726	0100X	3100X	Standard
		380	276 666	276 786	0100X	3100X	Standard
		460	276 616	276 716	0100X	3100X	Standard
30	34,5	230	276 607	276 727	0100X	3100X	Standard
		380	276 667	276 787	0100X	3100X	Standard
		460	276 617	276 717	0100X	3100X	Standard



6" HighTemp 90 Performance Data 50 Hz

P _N [kW]	Thrust F [N]	U _N [V]	n _N [min ⁻¹]	I _N [A]	I _A [A]	η (Eff.) [%] at % load			cos φ (Pf.) at % load			T _N [Nm]	T _A [Nm]
						50	75	100	50	75	100		
						3,7	45.000	380	2865	8,8	49,9		
	400	2880	8,5	52,5	66	72		75	0,74	0,82	0,86	12,3	31,4
	415	2890	8,4	54,5	65	72		75	0,70	0,79	0,84	12,3	34,2
5,5	45.000	380	2880	12,7	78,6	70	75	77	0,77	0,85	0,88	18,6	42,8
		400	2890	12,3	83,0	70	75	77	0,72	0,81	0,86	18,4	48,3
		415	2900	12,3	86,0	69	75	77	0,67	0,77	0,84	18,4	52,4
7,5	45.000	380	2880	16,4	105	74	78	80	0,76	0,84	0,88	24,7	68,1
		400	2890	16,0	110	74	79	81	0,69	0,79	0,85	24,5	76,6
		415	2900	16,1	114	71	77	80	0,65	0,76	0,83	24,5	83,4
11,0	45.000	380	2880	24,4	152	75	79	80	0,74	0,83	0,85	37,0	99,1
		400	2890	24,2	160	74	79	80	0,67	0,77	0,82	36,9	111,4
		415	2895	24,4	166	73	78	79	0,61	0,73	0,79	36,7	123,5
15,0	45.000	380	2865	33,3	195	76	79	80	0,73	0,82	0,87	49,6	143,7
		400	2885	33,0	205	75	79	80	0,65	0,77	0,83	49,4	161,3
		415	2890	33,3	213	74	78	80	0,60	0,72	0,80	49,2	196,6
18,5	45.000	380	2870	40,7	253	79	82	82	0,70	0,80	0,86	61,9	199,3
		400	2890	40,5	266	78	82	83	0,62	0,74	0,82	61,5	227,8
		415	2895	41,4	276	76	80	82	0,57	0,69	0,78	61,4	248,1
22	45.000	380	2870	49,2	289	76	79	80	0,76	0,83	0,88	74,3	196,6
		400	2885	48,0	304	75	79	81	0,70	0,80	0,85	74,0	221,0
		415	2895	47,9	316	74	79	80	0,65	0,76	0,82	73,8	241,3
30	45.000	380	2870	65,0	419	80	82	83	0,70	0,80	0,86	99,2	267,1
		400	2885	64,5	441	79	82	83	0,63	0,75	0,82	98,7	301,0
		415	2895	65,6	458	77	81	83	0,58	0,70	0,78	98,4	326,7

Electrical Connection

DOL

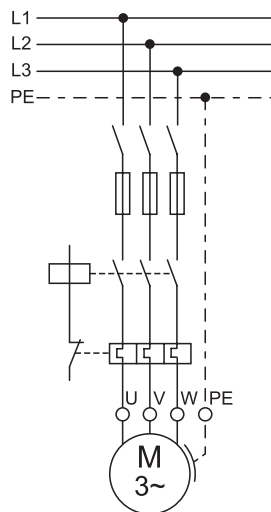

YD

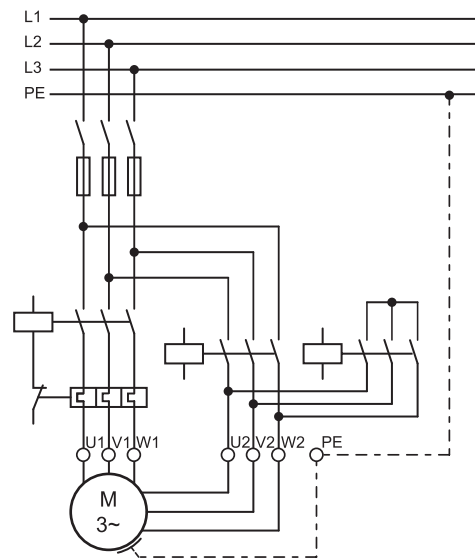

U	V	W	PE
black	white	red	green

6" HighTemp 90 Performance Data 60 Hz

P_N [kW]	P_{max} [kW]	Thrust [N]	U_N [V]	Hz	n_N [min ⁻¹]	I_{max} [A]	I_A [A]	LINE TO LINE RESISTANCE OHMS
4,0	4,6	45.000	230	60	3450	17.2	108	.68 - .84
			380	60	3450	10.4	66.0	2.0 - 2.4
			460	60	3450	8.6	54.0	2.8 - 3.4
			575	60	3450	6.9	43.0	4.7 - 5.7
5,5	6,3	45.000	230	60	3450	24.6	168	.41 - .50
			380	60	3450	14.9	102	1.1 - 1.4
			460	60	3450	12.3	84.0	1.7 - 2.0
			575	60	3450	9.9	67.0	2.6 - 3.2
7,5	8,6	45.000	230	60	3450	31.6	238	.28 - .35
			380	60	3450	19.2	144	.80 - .98
			460	60	3450	15.8	119	1.2 - 1.4
			575	60	3450	12.7	95.0	1.8 - 2.2
11	12,7	45.000	230	60	3450	47.4	354	.19 - .24
			380	60	3450	28.7	214	.52 - .65
			460	60	3450	23.7	177	.78 - .96
			575	60	3450	19.0	142	1.2 - 1.4
15	17,3	45.000	230	60	3450	64.0	418	.14 - .18
			380	60	3450	38.8	253	.41 - .51
			460	60	3450	32.0	209	.58 - .72
			575	60	3450	25.6	167	.93 - 1.15
18,5	21,3	45.000	230	60	3450	78.8	578	.11 - .14
			380	60	3450	47.7	350	.27 - .34
			460	60	3450	39.4	289	.41 - .51
			575	60	3450	31.6	231	.70 - .86
22	25,3	45.000	230	60	3450	94.4	640	.09 - .12
			380	60	3450	57.2	387	.23 - .29
			460	60	3450	47.2	320	.34 - .42
			575	60	3450	37.8	256	.52 - .65
30	34,5	45.000	380	60	3450	76.0	545	.18 - .23
			460	60	3450	62.8	450	.23 - .29
			575	60	3450	50.2	360	.34 - .43

6" High Temp 90 Motor Leads* 304 / 316SS

P_N [kW]	Jam Nut Material	L [m]	\emptyset [mm ²]	H [mm]	B [mm]	Part numbers
All Ratings	316 SS	5	3 x 8,4 mm ²	21,5 mm (±0,3mm)	9,4 mm (±0,3mm)	305 602 905
		8				305 602 906

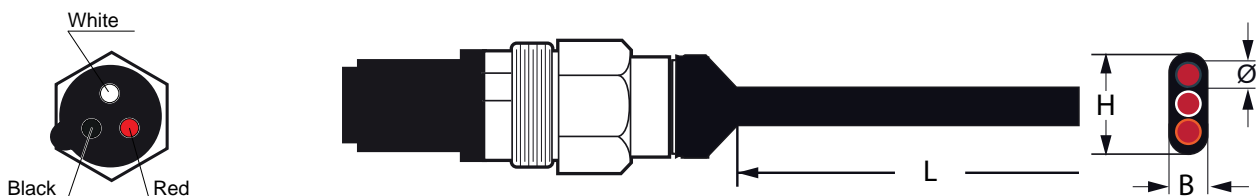

*Cables are designed for submerged operation. For air operation please consult Franklin Electric.



6" HighTemp 90 Encapsulated Cast Iron Version

4 - 30 kW

Kit A2	Thrust Bearing 15.500N	Incl.Pos.: 25; 26	308 750 120
Kit A3	Thrust Bearing 27.500N	Incl.Pos.: 26	308 750 200
Kit A4	Thrust Bearing 45.000N	Incl.Pos.: 26	308 750 510
45kN Conversion Kit A4 4,0 - 30kW		incl. Pos.: 12; 16; 17; 18; 19 ; 20; 21; 22; 23; 24; 26; 30	308 750 500
Kit B3	Seal Kit	Incl.Pos.: 4; 17; 20; 21, 41; 44	308 800 250
Kit C4	Slinger Kit	Incl.Pos.: 1; 2; 3; 37	308 725 155
Kit D5	Screw Kit	Incl.Pos.: 5; 19; 24	308 659 155
Kit E*	Radial Bearing Kit	Incl.Pos.: 12; 28	308 678 101

* Parts are unfinished

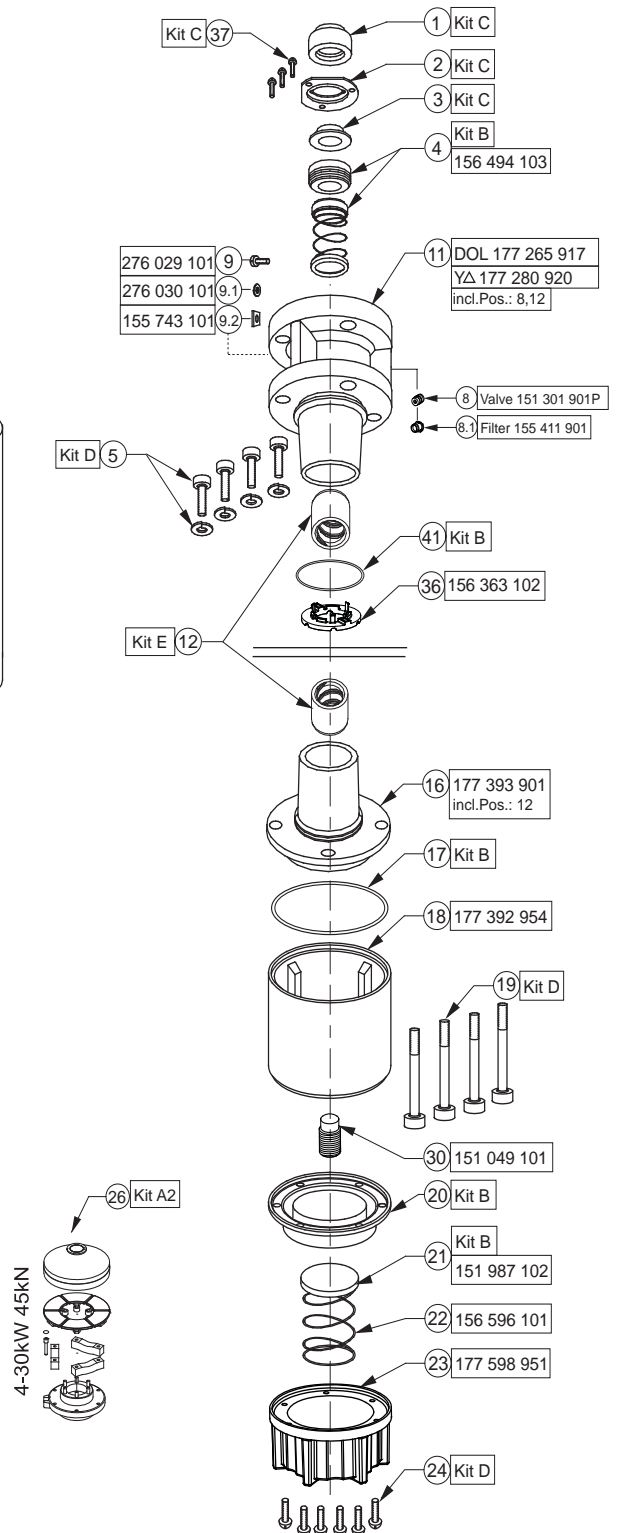
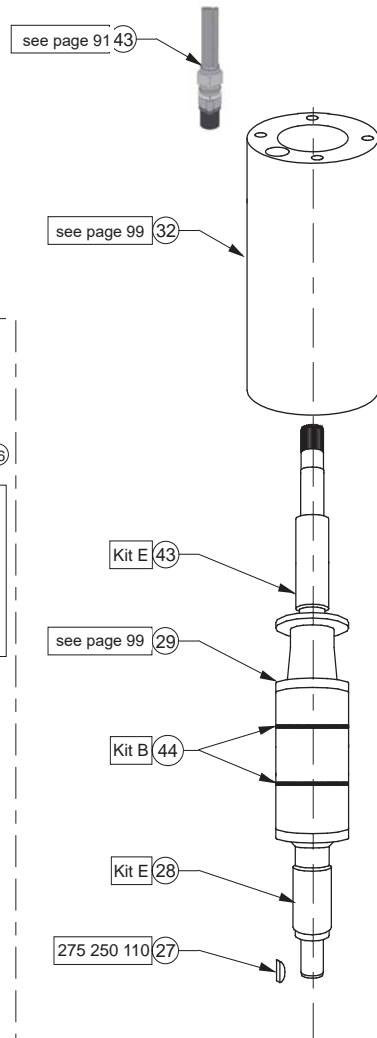
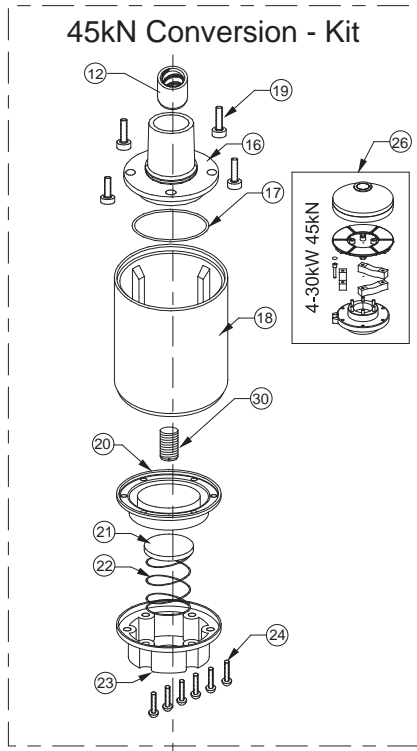

6" HighTemp 90 Encapsulated 316SS 4-30 kW

Kit A2	Thrust Bearing 15.500N	Inkl.Pos.: 25; 26	308 750 120
Kit A3	Thrust Bearing 27.500N	Inkl.Pos.: 26	308 750 200
Kit A4	Thrust Bearing 45.000N	Inkl.Pos.: 26	308 750 510
Kit B3	Seal Kit	Inkl.Pos.: 4; 17; 20; 21, 41; 44	308 800 250
Kit C4	Slinger Kit	Inkl.Pos.: 1; 2; 3; 37	308 725 155
Kit D5	Screw Kit	Inkl.Pos.: 5; 19; 24	308 659 155
Kit E*	Radial Bearing Kit	Inkl.Pos.: 12; 28	308 678 101

* Parts are unfinished

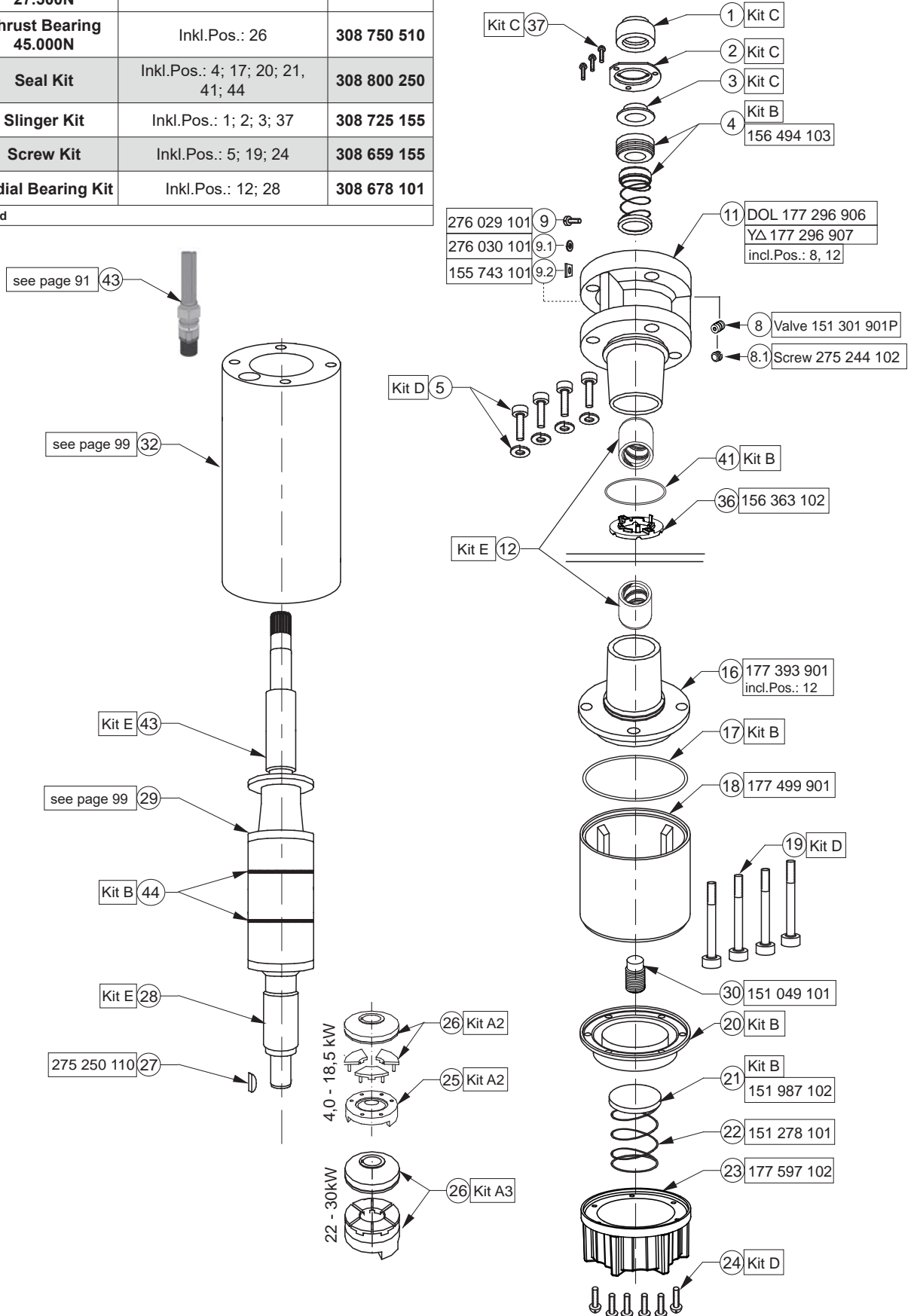



6" HighTemp 90 Replacement Stators and Rotors 50 Hz

P _N [kW]	U _N [V]	Thrust F [N]	DOL		YΔ		Rotor 316 Model No.
			Motor Model No.	Stator 316 Model No.	Motor Model No.	Stator 316 Model No.	
3,7	380 - 415	45.000	276 610 *****	331 634 903	276 710 *****	331 668 902	305 575 901
5,5	380 - 415	45.000	276 611 *****	331 635 903	276 711 *****	331 666 902	305 575 902
7,5	380 - 415	45.000	276 612 *****	331 636 903	276 712 *****	331 667 902	305 575 903
11,0	380 - 415	45.000	276 613 *****	305 482 974	276 713 *****	331 668 902	305 575 904
15,0	380 - 415	45.000	276 614 *****	331 616 903	276 714 *****	331 617 903	305 575 905
18,5	380 - 415	45.000	276 615 *****	305 485 972	276 715 *****	331 669 903	305 575 906
22,0	380 - 415	45.000	276 616 *****	305 486 976	276 716 *****	331 614 903	305 223 920
30,0	380 - 415	45.000	276 617 *****	305 490 913	276 717 *****	331 670 903	305 223 921

6" HighTemp 90 Replacement Stators and Rotors 60 Hz

P _{max} [kW]	U _N [V]	Thrust F [N]	DOL		YΔ		Rotor 316 Model No.
			Motor Model No.	Stator 316 Model No.	Motor Model No.	Stator 316 Model No.	
4,3	230	45.000	276 600	331 *** **	276 720	331 *** **	305 575 901
	380	45.000	276 660	331 *** **	276 780	331 *** **	
	460	45.000	276 610	331 *** **	276 710	331 *** **	
6,3	230	45.000	276 601	331 *** **	276 721	331 *** **	305 575 902
	380	45.000	276 661	331 *** **	276 781	331 *** **	
	460	45.000	276 611	331 *** **	276 711	331 *** **	
8,6	230	45.000	276 602	331 *** **	276 722	331 *** **	305 575 903
	380	45.000	276 662	331 *** **	276 782	331 *** **	
	460	45.000	276 612	331 *** **	276 712	331 *** **	
12,6	230	45.000	276 603	331 *** **	276 723	331 *** **	305 575 904
	380	45.000	276 663	331 *** **	276 783	331 *** **	
	460	45.000	276 613	331 *** **	276 713	331 *** **	
17,2	230	45.000	276 604	331 *** **	276 724	331 *** **	305 575 905
	380	45.000	276 664	331 *** **	276 784	331 *** **	
	460	45.000	276 614	331 *** **	276 714	331 *** **	
21,3	230	45.000	276 605	331 *** **	276 725	331 *** **	305 575 906
	380	45.000	276 665	331 *** **	276 785	331 *** **	
	460	45.000	276 615	305 485 902	276 715	331 *** **	
25,3	230	45.000	276 606	331 *** **	276 726	331 *** **	305 223 920
	380	45.000	276 666	331 *** **	276 786	331 *** **	
	460	45.000	276 616	331 *** **	276 716	331 *** **	
34,5	230	45.000	276 607	331 *** **	276 727	331 *** **	305 223 921
	380	45.000	276 667	331 *** **	276 787	331 *** **	
	460	45.000	276 617	331 *** **	276 717	331 *** **	

6" HighTemp 90 Motor Design 4 - 30 kW

304 / 316SS

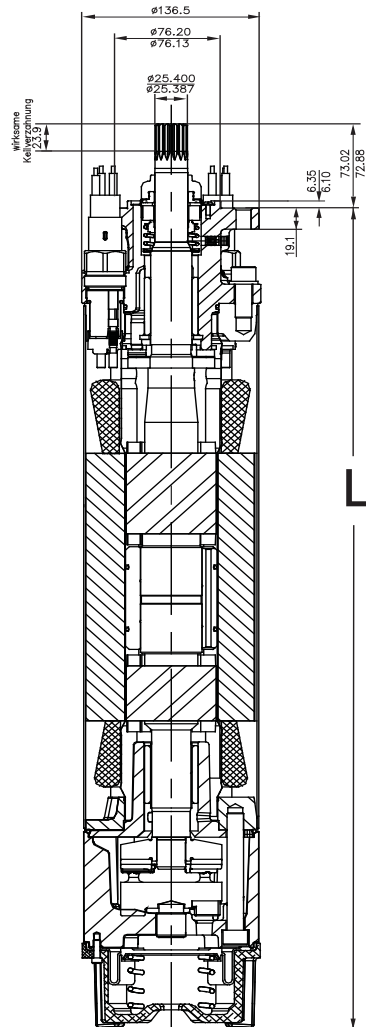

4 threaded holes
1/2-20 UNF-2B
hole circle - $\varnothing 111,2 \pm 0,3$

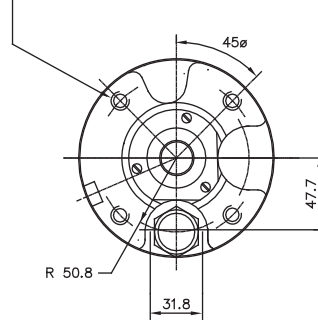

Material DIN / AISI		
Part	304	316 SS
Shell	1.4301	1.4571
Upper end bell	Cast iron powder coated	1.4408
Lower end bell	Cast iron	1.4401
Thrust housing	Cast iron powder coated	1.4408
Mechanical seal	SiC / SiC	SiC / SiC
Seal cover	1.4301	1.4401
Slinger	Viton	Viton
Shaft end	1.4305	1.4542
Diaphragm	Viton	Viton
Lead	EPR	EPR
Jam Nut (Lead)	1.4401	1.4401
Lead bushing	1.4401	1.4401

Motor Sizes				
P_N [kW]	304 L [mm]	316 L [mm]	Motor Package Size [mm]	Shipping Weight [kg]
4	716	716	222 x 267 x 876	53
5,5	752	752	222 x 267 x 940	59
7,5	780	780	222 x 267 x 1073	66
11	846	846	222 x 267 x 1073	71
15	909	909	222 x 267 x 1302	79
18,5	1041	1041	222 x 267 x 1302	92
22	1476,7	1476,7	223 x 267 x 1823	140
30	1629,2	1629,2	223 x 267 x 1823	156



Motor Filling Liquid

Filling liquid 5 L FES92					
4" Encapsulated	→	FES93	8" Encapsulated Standard	→	FES91
6" Encapsulated Standard	→	FES91	8" Encapsulated HighTemp75	→	FES92
6" Encapsulated HighTemp90	→	FES92	6" / 8" / 10" / 12" Rew Motors 6" / 8" Rew PM Motors		FES93



**Part number:
308 353 941**

FES91	FES92	FES93

Motor Filling Kit

This kit contains all necessary tools to check and replenish Franklin Electric submersible motors with FES 91, 92 or 93 filling liquid (fill solution/concentrate must be ordered separately).

Part number: 308 726 103





6" Motor – Pump Couplings

- Application:** Allow connection of pump to motors shaft.
- Specification:**
- Material: 304 / 316 SS
 - NEMA standard measuring on motor shaft
 - separation washer between motor & pump shafts

Outline Drawing:

6" Couplings

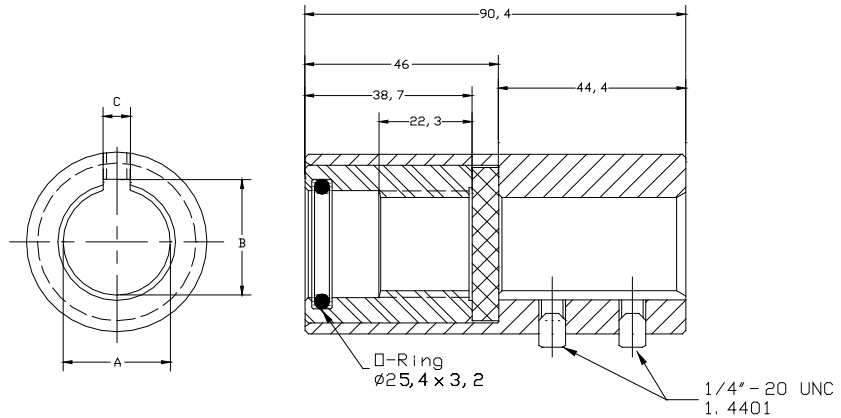

Ordering information

No.	Coupling Material DIN / AISI	Dimension A (mm) Max. / Min.	Dimension B (mm) Max. / Min.	Dimension C (mm) Max. / Min.
151 935 902	1.4005 (304)	19,075 / 19,063	20,70 / 20,52	4,84 / 4,79
151 935 922	1.4401 (316SS)			
151 935 910	1.4005 (304)	20,025 / 20, 013	22,76 / 22,60	6,05 / 6,00
151 935 927	1.4401 (316SS)			
151 935 908	1.4005 (304)	22,025 / 22,013	25,53 / 25,32	8,03 / 7,98
151 935 928	1.4401 (316SS)			
151 935 901	1.4005 (304)	22,250 / 22,238	24,54 / 24,36	6,43 / 6,38
151 935 921	1.4401 (316SS)			
151 935 906	1.4005 (304)	25,025 / 25, 013	28,70 / 28,30	8,03 / 7,98
151 935 926	1.4401 (316SS)			
151 935 909	1.4005 (304)	25,425 / 25,413	27,74 / 27,56	6,43 / 6,38
151 935 929	1.4401 (316SS)			

6" / 8" Encapsulated PT100 HighTemp

Its ohmic resistance is proportional to the sensed temperature. The FE field replaceable PT100 is potted into a screw holding the upper end bell. Because of his remote position relative to the windings, the sensing relay should be adjusted according to the below table.

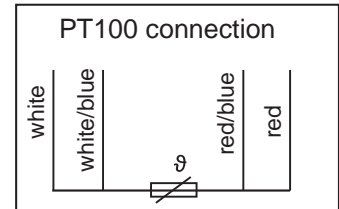
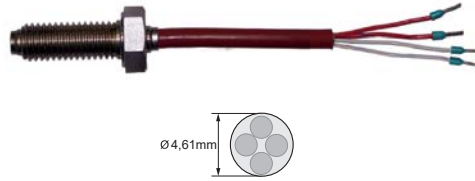
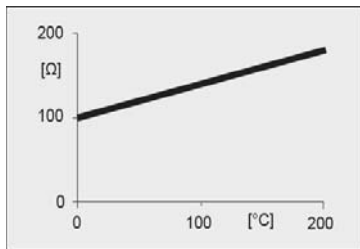

To install the PT100 sensor bolt, remove the top end bell bolt that is opposite of the lead and replace it with the PT100 screw. Tighten the sensor bolt to the torque values shown below.

6" PT100 - 4kW- 30kW 54- 61 Nm
 8" PT100 - 30kW- 110kW 115 - 122 Nm

Franklin Electric does not offer the required sensing device, it is available from speciality dealers.

Conditions	Temp. of the water without motor operation	Max. Trip temp. / Resistance Setting
Motor operating at nameplate output with 0.16 m/sec flow past the motor	50°C	60°C
	60°C	70°C
	70°C	80°C
	75°C	85°C
	80°C	90°C
	90°C	100°C

6" PT100 HighTemp90

Kit Number	Motor Type	Wire Insul.	max. Medium Temp.	Lead (mm ²)	Lead length (m)
156 098 111K	4 - 30kW	Silicon	90°C	4X0,35	10
156 098 112K		Silicon	90°C	4X0,35	130

8" PT100 HighTemp75

Kit Number	Motor Type	Wire Insul.	max. Medium Temp.	Lead (mm ²)	Lead length (m)
156 098 116K	30 - 110kW (Type 1)	Silicon	90°C	4X0,35	10
156 098 117K		Silicon	90°C	4X0,35	130



6" Permanent Star Plug

For some applications it may be necessary to permanently run a star-delta submersible motor in star connection. This may be achieved by using the PERMANENT-STAR-PLUG . This connector short - circuits all three pins in one of the two motor sockets and is designed to replace one lead.



Part- Nb.: 304- 308 065 901

Part- Nb.: 316SS - 308 065 951

Surge Arrestor

These surge arrestors or their equivalents are highly recommended for protecting submersible motors from a variety of commonly occurring high voltage spikes which can damage the motor insulation system and cause motor winding failure. These arrestors will not, as is true of any surge protection equipment, protect the motor from a direct lightning strike.



Part-Nb.: 155 440 902

6" CT - Pump connection screw Kit's

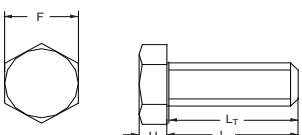
	Material	L / L _T [mm]	H [mm]	F [mm]	Mod.- No.:
	316SS	38,1	8	19	308 659 318



Franklin Electric Europa GmbH
Rudolf Diesel Strasse 20
54516 Wittlich / Germany

franklinwater.eu

DOC.NB. 308-018-626 EN REV. 19 012018